

## Installation Manual

### L.D94.C.M(.A)

**Citroën Jumper / Relay X230 (1994–2002)**

**Fiat Ducato X230 (1994–2002)**

**Peugeot Boxer X230 (1994–2002)**





Citroën Jumper X230

Fiat Ducato X230

Peugeot Boxer X230

## L.D94.C.M & L.D94.C.M.A

### CONTENTS

1. FOREWORD .....	3
2. INTRODUCTION .....	4
3. VERY IMPORTANT NOTES.....	5
4. COMPLETE ASSEMBLY .....	7
5. INSTRUCTIONS FOR INSTALLATION .....	9
5.1. Attachment of Lower Bracket to Bellow. ....	9
5.2. Bump Stop Removal and Fitting of Upper Bracket.....	9
5.3. Fitting of Lower Bracket and Bellow .....	10
5.4. Fitting of Inflator Console .....	11
5.5. Tube Connection and Disconnection, Cutting and Routing .....	12
5.6. Spring Inflation.....	13
5.7. Spring Alignment .....	14
5.8. <b>IMPORTANT!</b> Load Sensing Valve (LSV) Adjustment .....	14
5.9. Maintenance.....	15
5.10. Installation Drawings .....	16
6. EPILOGUE .....	21

Dunlop Systems and Components  
 Het Wegdam 22  
 7496 CA Hengevelde  
 Nederland  
 Tel. +31 (0)547 33 30 65  
 Fax. +31 (0)547 33 30 68

Dunlop Systems and Components  
 Holbrook Lane  
 Coventry CV6 4QX  
 United Kingdom  
 Tel. +44 (0)24 7629 3300  
 Fax. +44 (0)24 7629 3390

[www.dunlopsystems.com](http://www.dunlopsystems.com)

© 2008, *Dunlop Systems and Components*

**FIAT****DUNLOP**  
SYSTEMS AND COMPONENTS

Citroën Jumper X230

Fiat Ducato X230

Peugeot Boxer X230

**L.D94.C.M & L.D94.C.M.A****1. FOREWORD**

This manual provides instructions for the installation of an auxiliary air suspension kit, developed specifically for the Citroën Jumper/Relay X230, Fiat Ducato X230 and Peugeot Boxer X230. To ensure correct installation of the kit, it is strongly recommend that these instructions are read thoroughly before commencing any installation work. Installation should only be carried out by a suitably qualified mechanic or specialist installation facility. Dunlop Systems and Components will not accept any responsibility for faults or defects arising from incorrect installation, which automatically renders the guarantee invalid.

**IMPORTANT : Manufacturer's Declaration Form**

**A manufacturer's declaration form is provided with your kit. Following installation of the kit please ensure that this form is completed, signed by a qualified fitter and returned to Dunlop Systems and Components.**

This kit is suitable for motorhomes and other vehicles with a minimum rear axle load of 1550kg (3417lbs).

**FIAT****DUNLOP**  
SYSTEMS AND COMPONENTS

Citroën Jumper X230

Fiat Ducato X230

Peugeot Boxer X230

## L.D94.C.M & L.D94.C.M.A

### 2. INTRODUCTION

Thank you for choosing an auxiliary air suspension kit from the range offered by *Dunlop Systems and Components*. Auxiliary air suspension is fitted in tandem with the standard steel springs of the vehicle suspension, and provides enhancements in terms of both the stability of the vehicle and the comfort of the passengers...

#### **Vehicle Levelling**

Simply by varying the air pressure in the springs, the vehicle can be levelled both front-to-rear and side-to-side. Keeping the vehicle level optimises stability, ensures correct headlamp beam distribution and reduces tyre wear arising from uneven distribution of weight.

#### **Straight Line Stability**

Straight line stability is greatly increased at higher speeds, and when subjected to buffeting from cross-winds or large overtaking vehicles

#### **Reduced Body Roll**

Body roll when cornering or negotiating roundabouts is significantly reduced.

#### **Fatigue Reduction and Wear Compensation**

Suspension fatigue is reduced, so helping to prevent leaf springs from sagging under repeated or constant loading.

Any sagging already present can be compensated-for. This is a particular benefit for motorhomes, which are always fully laden.

#### **Ride Comfort**

Air springs help to absorb shock loads from uneven road surfaces, therefore general ride quality is much improved.

**FIAT****DUNLOP**  
SYSTEMS AND COMPONENTS

Citroën Jumper X230

Fiat Ducato X230

Peugeot Boxer X230

## L.D94.C.M & L.D94.C.M.A

### 3. VERY IMPORTANT NOTES



#### Gross Vehicle Weight (GVW)

**Air assist kits are not in themselves designed to increase the gross vehicle weight (GVW) rating of a vehicle.** They do not legally allow for carriage of a load greater than the carrying capacity stated on the data plate of the vehicle.

Do not exceed the maximum load specified by the vehicle manufacturer...

- ◆ to avoid compromising passenger safety
- ◆ to prevent possible damage to the vehicle
- ◆ for legal reasons



#### Load Sensing Valve (LSV) Adjustment

If your vehicle is not fitted with an antilock braking system (ABS) then it will have a load sensing valve (LSV) to automatically adjust braking force under varying load conditions. This valve **must** be adjusted immediately after the fitting of an air assist kit and before the vehicle is driven again on public roads.

If the LSV is not adjusted following the fitting of an air assist kit, it may misjudge rear load conditions to the extent that the braking pressure applied to the rear brakes is not correct (e.g. the rear wheels may lock with no load on the rear axle). The consequences of this in terms of vehicle stability and safety are potentially serious.

### Vehicle Upgrading

Despite the above words of caution, it is possible to upgrade the weight rating of your vehicle. This must be carried-out by a specialist supplier that will...

- ◆ carry out any necessary modifications in addition to fitting the air assist kit
- ◆ complete documentation as necessary to inform the Vehicle and Operator Services Agency (VOSA) – a mandatory requirement
- ◆ supply and fit a new weight plate to replace the original plate supplied with the vehicle

This process applies to United Kingdom registered vehicles. The process in other countries may be different.



**FIAT**



**DUNLOP**  
SYSTEMS AND COMPONENTS

Citroën Jumper X230

Fiat Ducato X230

Peugeot Boxer X230

## **L.D94.C.M & L.D94.C.M.A**

### **Safety Guidance Note**

The following very useful guidance note is available for free download from the *Health and Safety Executive* (HSE)...

**PM85, July 2007** *Safe recovery (and repair) of buses and coaches fitted with air suspension*

The uniform resource locator (URL) for this document is...

<http://www.hse.gov.uk/PUBNS/pm85.pdf>



Citroën Jumper X230

Fiat Ducato X230

Peugeot Boxer X230

## L.D94.C.M & L.D94.C.M.A

### 4. COMPLETE ASSEMBLY

The complete bellow and bracket assembly is shown by the diagram below...

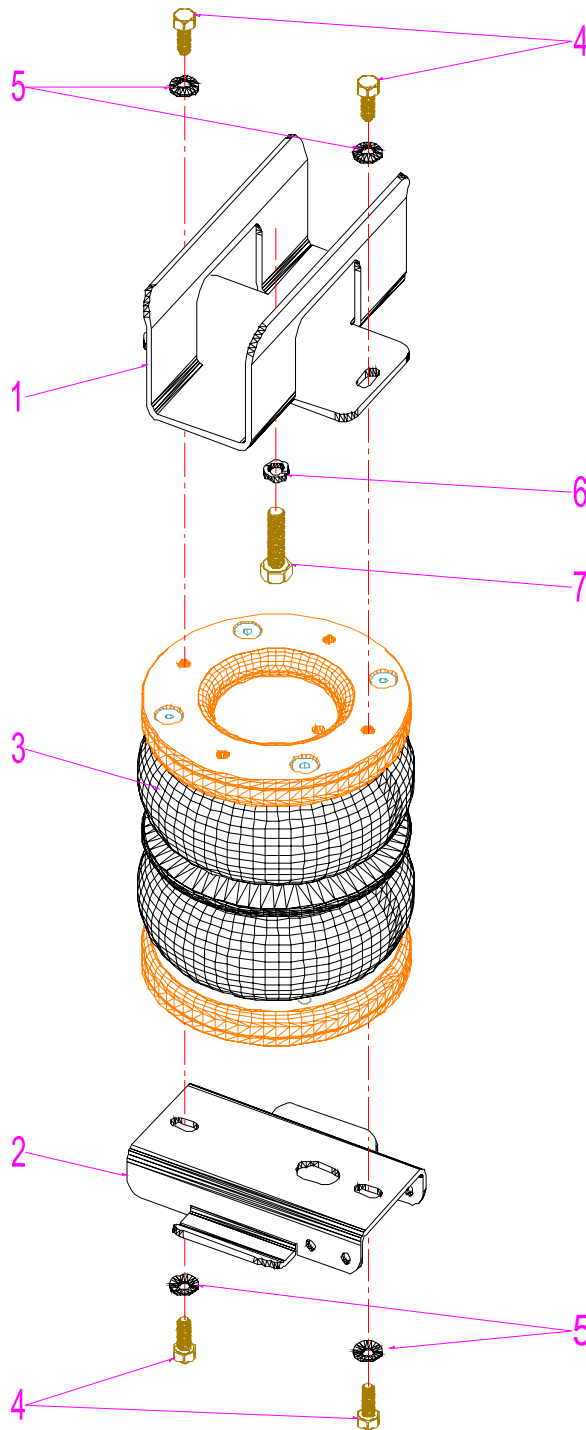

1	Upper Bracket
2	Lower Bracket
3	Air Bellow : 170/2
4	Bolt : M8 x 16
5	Spring Washer : M8
6	Spring Washer : M10
7	Bolt : M10 x 1.25 x 30



**FIAT**



**DUNLOP**  
SYSTEMS AND COMPONENTS

Citroën Jumper X230

Fiat Ducato X230

Peugeot Boxer X230

## L.D94.C.M & L.D94.C.M.A

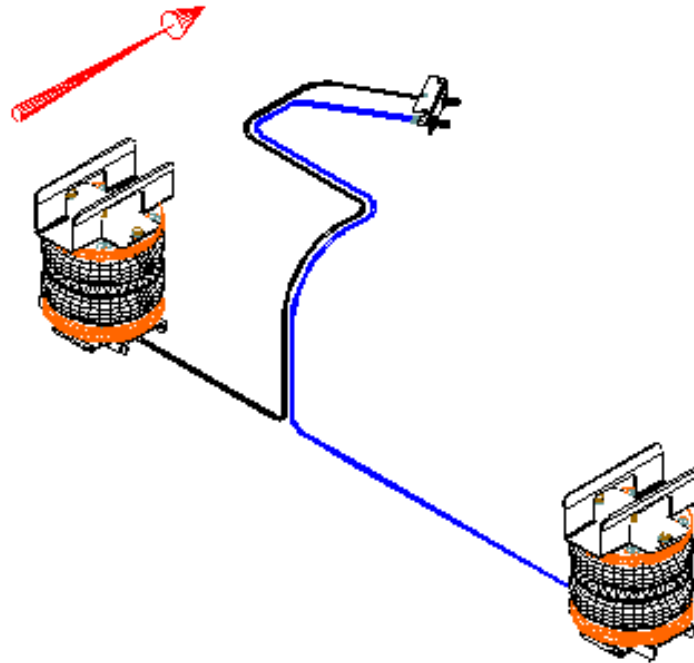

System for vehicles with ABS

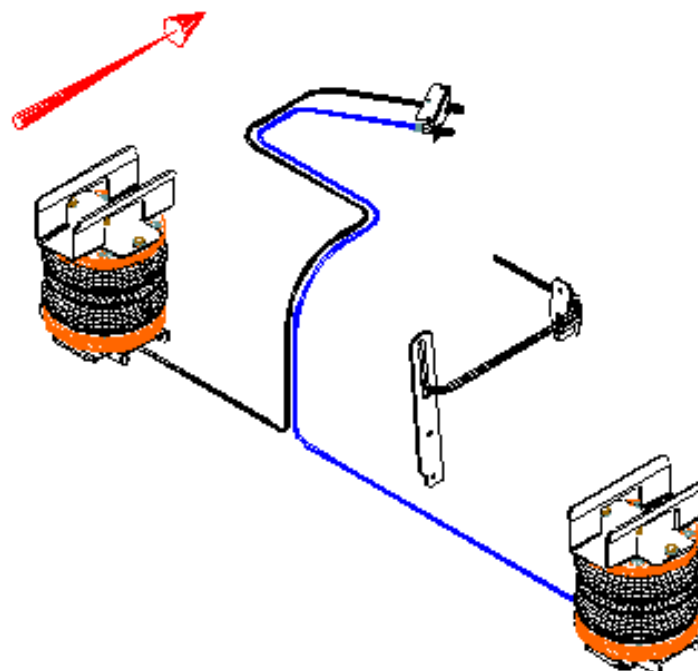

System for vehicles without ABS

**FIAT****DUNLOP**  
SYSTEMS AND COMPONENTS

Citroën Jumper X230

Fiat Ducato X230

Peugeot Boxer X230

**L.D94.C.M & L.D94.C.M.A****5. INSTRUCTIONS FOR INSTALLATION****Preparation and Precaution**

Before beginning installation, ensure that you have sufficient clearance between the axle and the chassis. Use a jack if necessary. Install at one side of the vehicle at a time.



Pay attention to your safety at all times during installation - always use axle stands to support the vehicle!

The following instructions make reference to the diagrams on pages 17 to 19 inclusive.

**5.1 Attachment of Lower Bracket to Bellow**

Attach the lower bracket to the bellow as indicated by the diagram of Section 4. Do not fully tighten at this stage because...

(i) otherwise it may prove difficult or impossible to slot the U-bolts between the lower plate of the bellow and the lower bracket (in step 4 of section 5.3).

(ii) the bellow may require alignment once inflated (see Section 5.7, Figure 24)

**5.2 Bump Stop Removal and Fitting of Upper Bracket**

- i. Unscrew and remove the bump stop — Figures 1 and 2. The hole vacated by removal of the bump stop will be used for attachment of the upper bracket.
- ii. Attach the upper bracket to the chassis using the M10 x 1.25 x 30mm bolt and M10 spring washer — Figures 3 and 4.

**FIAT****DUNLOP**  
SYSTEMS AND COMPONENTS

Citroën Jumper X230

Fiat Ducato X230

Peugeot Boxer X230

## L.D94.C.M & L.D94.C.M.A

### 5.3 Fitting of Lower Bracket and Bellow

- i. See Section 5.5 - "*Tube Connection and Disconnection, Cutting and Routing*" : Connect a tube to the bellow by pushing the tube into the air inlet port on the underside of the spring and then hand-rotating the tube by one screw turn. Use black tubing for the left-hand bellow and blue for the right-hand bellow.
- ii. Remove the U-bolts that attach a clamping plate to the leaf spring and then remove and discard the plate itself — Figures 5, 6 and 7
- iii. See figures 8, 9, 10 and 11 : Place the bellow over the leaf spring paying attention to orientation—see arrows on Figures 8 and 9. Also observe the routing of the air pipe from the side of the bracket—Figure 11.
- iv. Place the U-bolts over the lower bracket and through their original mounting holes. Secure the bolts using four flat washers, four spring washers and four nuts—Figures 8 and 9. Tighten all four nuts to torque 110Nm (81lbf.ft).
- v. Attach the top plate of the bellow to the upper bracket using two M8 x 16 bolts and two M8 spring washers—Figures 12 and 13. Do not fully tighten at this stage because the bellow may require alignment once inflated (see Section 5.7, Figure 24)
- vi. Attach the bottom plate of the bellow to the lower bracket using two M8 x 16 bolts and two M8 spring washers—Figures 12 and 13. Note that access to these bolts is now a little restricted but is still possible. Do not fully tighten at this stage because the bellow may require alignment once inflated (see Section 5.7, Figure 24).

**FIAT****PEUGEOT****DUNLOP**  
SYSTEMS AND COMPONENTS

Citroën Jumper X230

Fiat Ducato X230

Peugeot Boxer X230

**L.D94.C.M & L.D94.C.M.A****5.4 Fitting of Inflater Console****Standard****Option 1****Option 2****Option 3**

Your kit is supplied either with the standard inflator console having two valves only (above, top-left), or an optional console having both valves and pressure gauges (Option 1, Option 2 or Option 3 above). Mount the console in a position of your choice whereby it is firmly fixed, has some protection from the environment (particularly important for a console with gauges) and is easily accessible. Suggested possible locations

**Console with Valves Only...**

- on the rear bumper
- at the rear beside the license plate
- on the chassis next to a rear wheel
- in a service shutter
- beside the fuel cap

**Console with Valves and Gauges...**

- in the vehicle cabin, within reach and sight of the driver
- in the wall of a cupboard (motorhomes)
- in a service shutter

**'Comfort' Packages**

The 'Option 2' and 'Option 3' panels, as shown above, are each part of a *Comfort Package* that is supplied with a compressor (and also an air reservoir in the case of the 'Option 3' panel) for ease of spring inflation and ride height setting. For further information please ask your dealer.



FIAT



**DUNLOP**  
SYSTEMS AND COMPONENTS

Citroën Jumper X230

Fiat Ducato X230

Peugeot Boxer X230

## L.D94.C.M & L.D94.C.M.A

### 5.5 Tube Connection and Disconnection, Cutting and Routing

#### Connection and Disconnection

Tubes are connected as shown by the diagrams below...

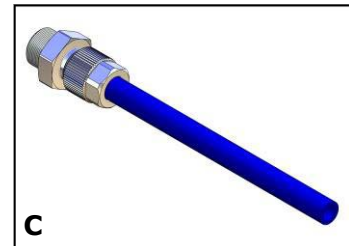
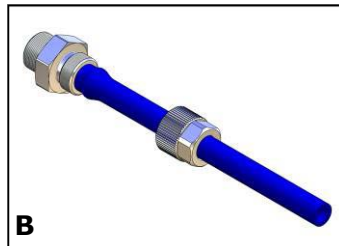
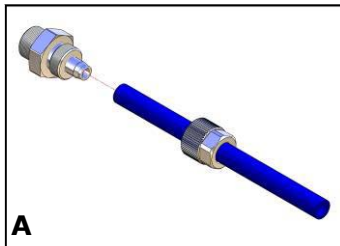

- Slide a nut over the end of the tube
- Push the tube onto the connector as far as possible
- Feed the nut up to the connector, fully tighten by hand and finally tighten one additional turn using spanners

#### Cutting

To achieve good sealing and air-tight fitting of tube ends to their connecting parts, it is very important to cut tubing cleanly and squarely. A dedicated guillotine action tubing cutter is recommended, or a craft knife if such a tool is not available. Do not use electrician's side cutters.



A dedicated tubing cutter -  
**Recommended**



Electrician's Side Cutters  
**NOT Recommended**

**FIAT****DUNLOP**  
SYSTEMS AND COMPONENTS

Citroën Jumper X230

Fiat Ducato X230

Peugeot Boxer X230

## L.D94.C.M & L.D94.C.M.A

### Routing

Study the underside of the vehicle and decide how to route each branch of the air circuit...

- To minimise the risk of chafing, avoid running tubing over metal edges as much as possible
- Avoid close proximity to heat sources such as the exhaust assembly
- Choose a route that provides as much protection as possible from dirt, debris and any solid objects that may impact the underside of the vehicle

It is recommended that tubes are guided alongside brake lines as much as possible.



Use cable ties ('tie wraps') to secure tubing to the chassis, taking care not to over-tighten them.

### 5.6 Spring Inflation

Once installation of the air assist kit is complete, inflate the springs via the inflator console taking careful note of the following...



#### Maximum and Minimum Pressure

**Maximum Pressure 7.0bar****Minimum Pressure 0.5bar**

Do not exceed 7.0bar (101psi), which is the recommended maximum charge pressure for the air springs.

The springs may be deflated if the vehicle is to be stored for a lengthy period without use, but a pressure of at least 0.5bar (7.25psi) should be maintained at all times in order to avoid possible compression damage to the springs.

**FIAT****DUNLOP**  
SYSTEMS AND COMPONENTS

Citroën Jumper X230

Fiat Ducato X230

Peugeot Boxer X230

## L.D94.C.M & L.D94.C.M.A

### 5.7 Spring Alignment

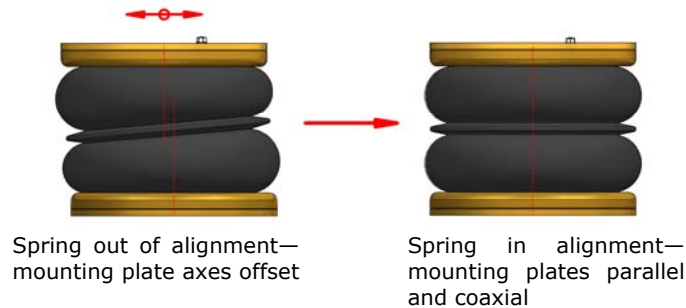

#### CAUTION!

Before fully tightening the bolts that secure the air spring to the upper and lower brackets, set the vehicle at ride height (spring height approximately 13.5cm) and ensure that the springs are correctly aligned.

### 5.8 IMPORTANT! Load Sensing Valve (LSV) Adjustment

Once the auxiliary air suspension system is installed and the bellows are inflated such that the desired vehicle ride height is achieved, the LSV assembly must be modified—see Figures 15 to 24 inclusive. This involves fitting two brackets, as supplied in your kit, to the existing assembly.

- i. Detach and remove the upper of the two interconnected brackets—Figures 15 to 18
- ii. Detach the LSV rod hinge from its supporting bracket—Figure 19
- iii. Mate the adaptor bracket to the hinge-supporting bracket and then reattach the hinge—Figures 20 and 21
- iv. Attach the slotted bracket supplied to the existing LSV axle bracket, with the exposed end of the LSV rod through the slot in the bracket—Figures 22 and 23
- v. Secure the exposed end of the LSV rod to the slotted bracket by push-fitting the clamping ring provided—Figure 24

**FIAT****DUNLOP**  
SYSTEMS AND COMPONENTS

Citroën Jumper X230

Fiat Ducato X230

Peugeot Boxer X230

**L.D94.C.M & L.D94.C.M.A****5.9 Maintenance**

Following installation, it is recommended that all metal parts are coated with a protective substance such as body wax.

The system does not require very much maintenance other than...

- ♦ to maintain air pressure in the springs. Much like a tyre, the system may lose a little air over time.
- ♦ to keep the air bellows clean. It is suggested that, when washing the vehicle, the bellows are inspected and cleaned as necessary (preferable by spraying). Look in particular for stones or grit trapped between convolutes, as this may damage the bellow.



**FIAT**



**DUNLOP**  
SYSTEMS AND COMPONENTS

Citroën Jumper X230

Fiat Ducato X230

Peugeot Boxer X230

## L.D94.C.M & L.D94.C.M.A

### 5.10 Installation Drawings

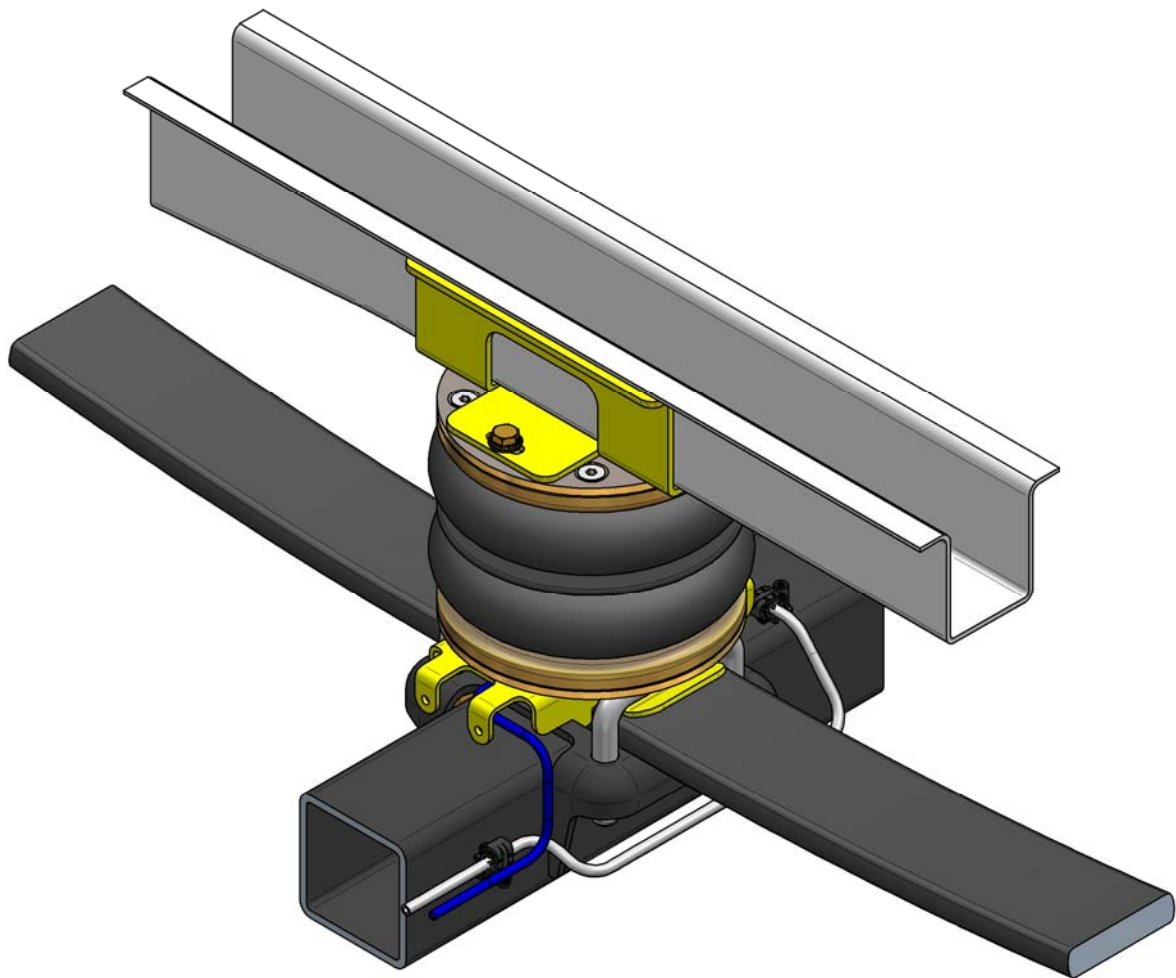



**FIAT**



**DUNLOP**  
SYSTEMS AND COMPONENTS

Citroën Jumper X230

Fiat Ducato X230

Peugeot Boxer X230

## L.D94.C.M & L.D94.C.M.A

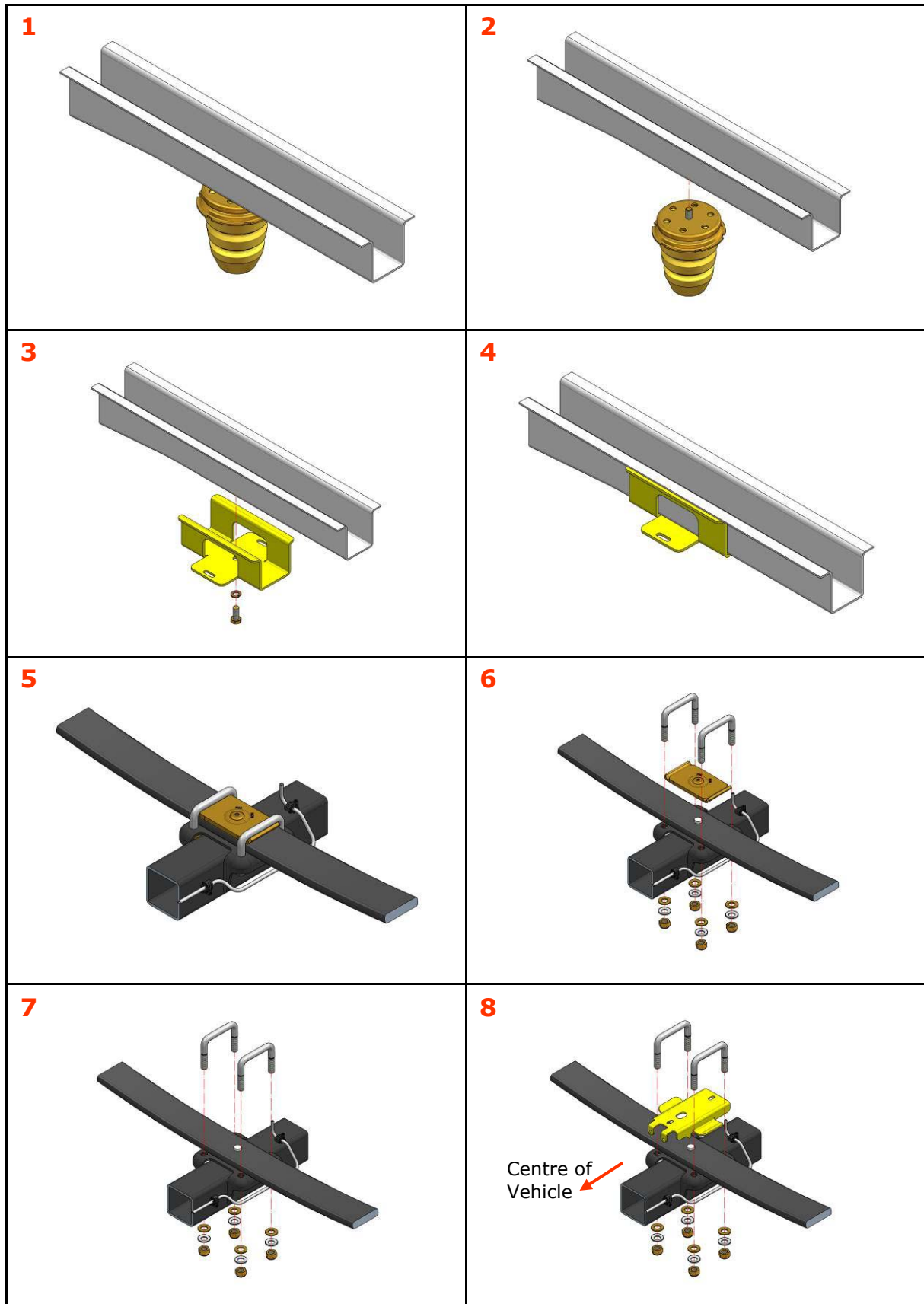



FIAT



**DUNLOP**  
SYSTEMS AND COMPONENTS

Citroën Jumper X230

Fiat Ducato X230

Peugeot Boxer X230

## L.D94.C.M & L.D94.C.M.A

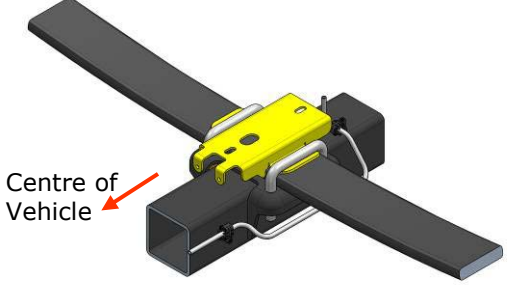
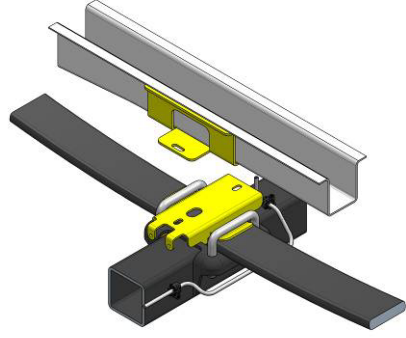
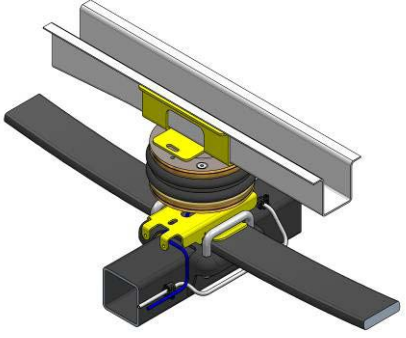
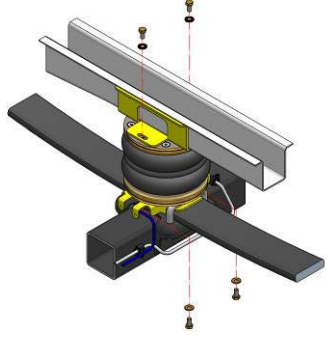
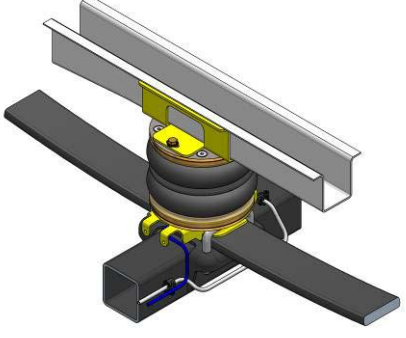
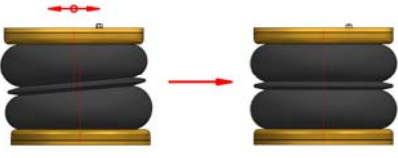
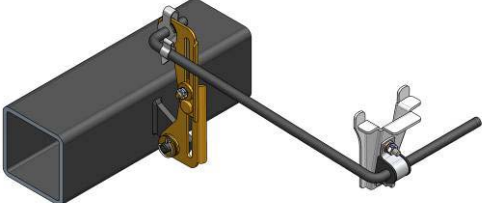
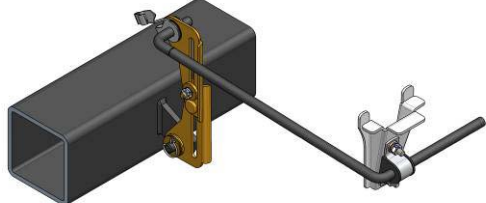
<p><b>9</b></p>  <p>Centre of Vehicle</p>	<p><b>10</b></p> 
<p><b>11</b></p> 	<p><b>12</b></p> 
<p><b>13</b></p> 	<p><b>14</b></p>  <p>Spring out of alignment—mounting plate axes offset      Spring in alignment—mounting plates parallel and coaxial</p> <p><b>CAUTION!</b> Before fully tightening the bolts that secure the air spring to the upper and lower brackets, set the vehicle at ride height (spring height approximately 13.5cm) and ensure that the springs are correctly aligned.</p>
<p><b>15</b></p> 	<p><b>16</b></p> 



**FIAT**



**DUNLOP**  
SYSTEMS AND COMPONENTS

Citroën Jumper X230

Fiat Ducato X230

Peugeot Boxer X230

## L.D94.C.M & L.D94.C.M.A

**17**

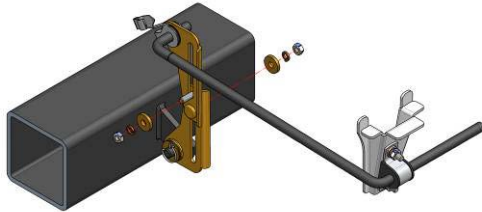

**18**

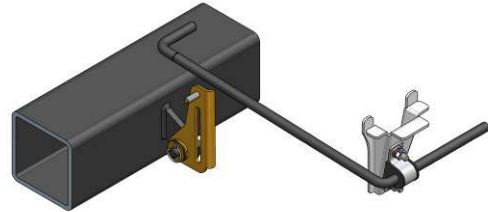

**19**

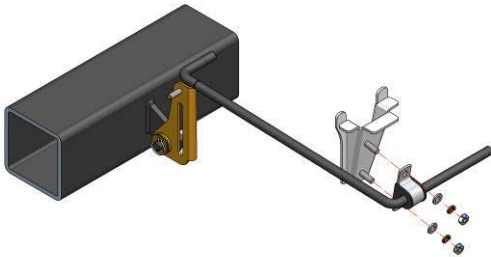

**20**

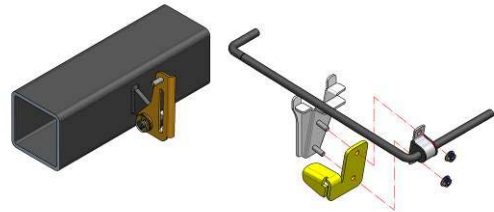

**21**

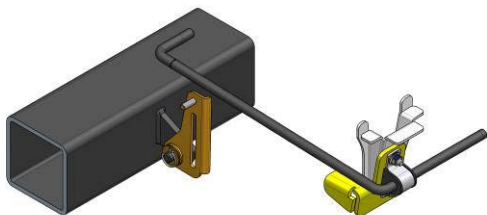

**22**

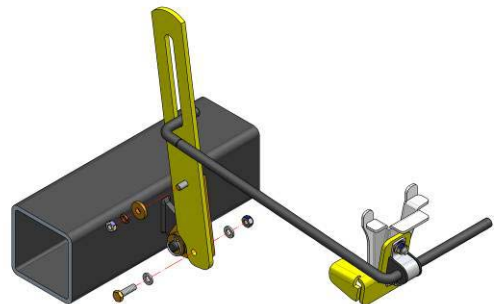

**23**

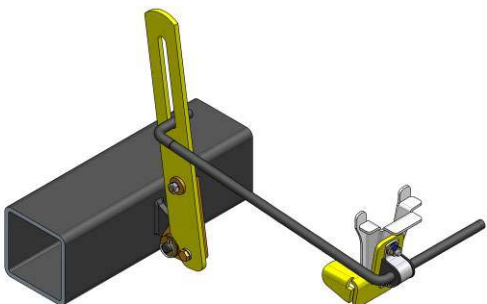

**24**

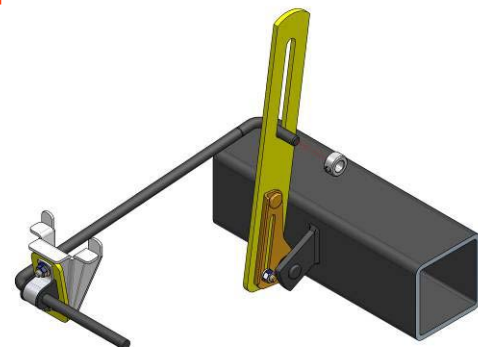

**FIAT****DUNLOP**  
SYSTEMS AND COMPONENTS

Citroën Jumper X230

Fiat Ducato X230

Peugeot Boxer X230

**L.D94.C.M & L.D94.C.M.A****6. EPILOGUE**

Dunlop Systems and Components hopes that you enjoy the benefits that your air suspension system will provide for you. To ensure optimal performance, we advise that you have your system checked frequently by qualified personnel. As recommended in the fitting instructions, it is important to coat all the steel parts with a protective substance such as body wax.

**IMPORTANT : Manufacturer's Declaration Form**

**A manufacturer's declaration form is provided with your kit. Following installation of the kit please ensure that this form is completed, signed by a qualified fitter and returned to Dunlop Systems and Components.**

As a condition of your warranty, modifications to the system may only be carried out by personnel of Dunlop Systems and Components.

**Enquiries**

For general enquiries please either telephone...

Dunlop Systems and Components Nederland : +31 (0)547 33 30 65

Dunlop Systems and Components UK : +44 (0)24 7629 3300

...or e-mail [info@dunlopsystems.com](mailto:info@dunlopsystems.com).

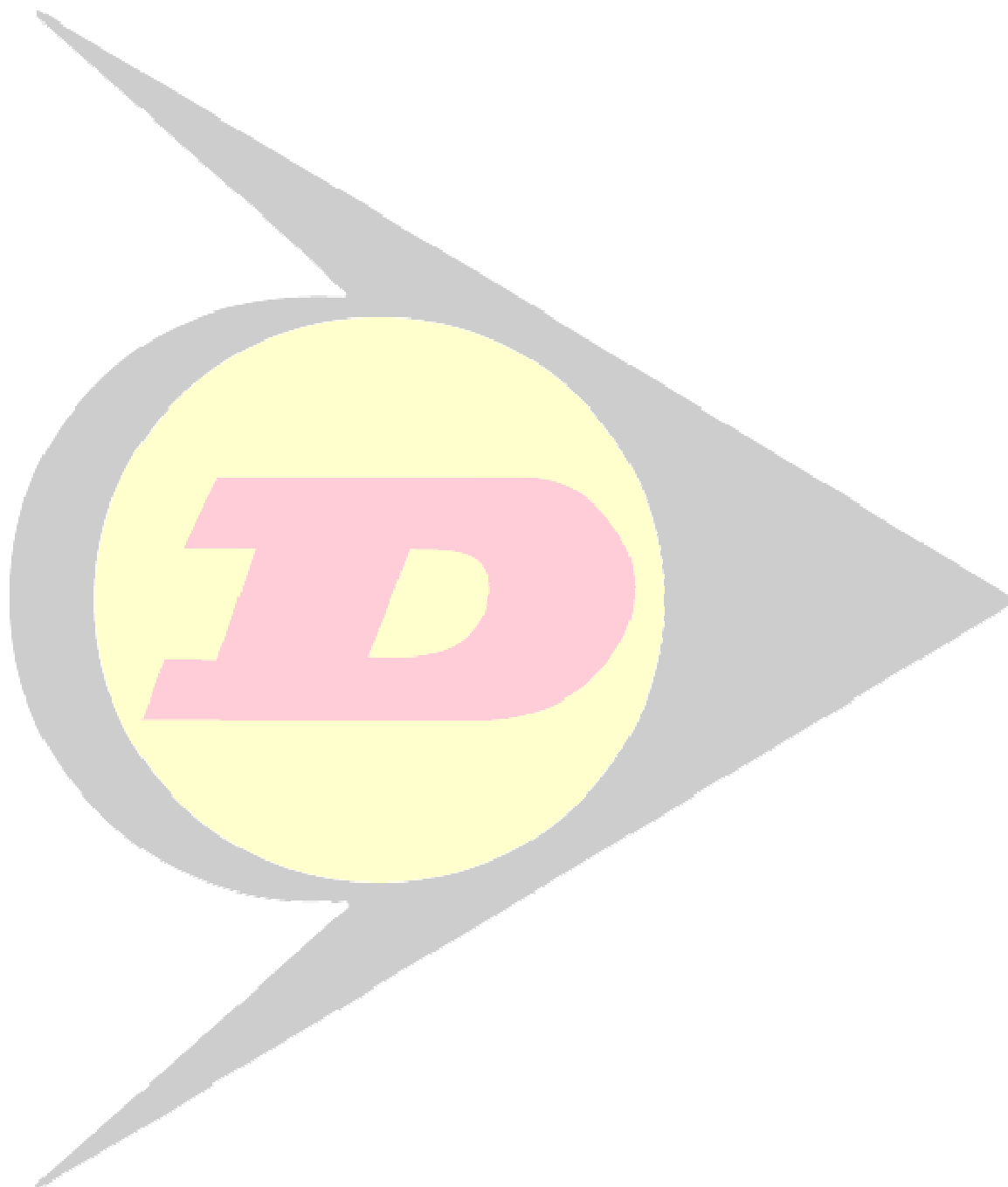

Dunlop Systems and Components  
Het Wegdam 22  
7496 CA Hengevelde  
Nederland  
Tel. +31 (0)547 33 30 65  
Fax. +31 (0)547 33 30 68

Dunlop Systems and Components  
Holbrook Lane  
Coventry CV6 4QX  
United Kingdom  
Tel. +44 (0)24 7629 3300  
Fax. +44 (0)24 7629 3390

[www.dunlopsystems.com](http://www.dunlopsystems.com)