

Installation Manual



L.NAV.05.C.M Nissan Navara





Nissan Navara

L.NAV.05.C.M

CONTENTS

1. FOREWORD	3
2. INTRODUCTION	4
3. VERY IMPORTANT NOTES	5
4. COMPLETE ASSEMBLY	7
5. INSTRUCTIONS FOR INSTALLATION	8
5.1. Installation of lower plate	8
5.2. Attaching top plate to chassis	9
5.3. Upper Attachment of Bellow	9
5.4. Attaching the air spring to the lower plate	9
5.5. Spring alignment	9
5.6. Fitting of Inflator Console	10
5.7. Tube Connection and Disconnection, Cutting and Routing	11
5.8. Spring Inflation	12
5.9. Maintenance	12
5.10. Installation Drawings	13
6. EPILOGUE	17

Dunlop Systems and Components
Het Wegdam 22
7496 CA Hengevelde
Nederland
Tel. +31 (0)547 33 30 65
Fax. +31 (0)547 33 30 68

Dunlop Systems and Components
Holbrook Lane
Coventry CV6 4QX
United Kingdom
Tel. +44 (0)24 7629 3300
Fax. +44 (0)24 7629 3390

www.dunlopsystems.com

© 2008, *Dunlop Systems and Components*



Nissan Navara

L.NAV.05.C.M

1. FOREWORD

This manual provides instructions for the installation of an auxiliary air suspension kit, developed specifically for the Nissan Navara . To ensure correct installation of the kit, it is strongly recommend that these instructions are read thoroughly before commencing any installation work. Installation should only be carried out by a suitably qualified mechanic or specialist installation facility. Dunlop Systems and Components will not accept any responsibility for faults or defects arising from incorrect installation, which automatically renders the guarantee invalid.

IMPORTANT : Manufacturer's Declaration Form

A manufacturer's declaration form is provided with your kit. Following installation of the kit please ensure that this form is completed, signed by a qualified fitter and a copy is returned to Dunlop Systems and Components.



Nissan Navara

L.NAV.05.C.M

2. INTRODUCTION

Thank you for choosing an auxiliary air suspension kit from the range offered by *Dunlop Systems and Components*. Auxiliary air suspension is fitted in tandem with the standard steel springs of the vehicle suspension, and provides enhancements in terms of both the stability of the vehicle and the comfort of the passengers...

Vehicle Levelling

Simply by varying the air pressure in the springs, the vehicle can be levelled both front-to-rear and side-to-side. Keeping the vehicle level optimises stability, ensures correct headlamp beam distribution and reduces tyre wear arising from uneven distribution of weight.

Straight Line Stability

Straight line stability is greatly increased at higher speeds, and when subjected to buffeting from cross-winds or large overtaking vehicles.

Reduced Body Roll

Body roll when cornering or negotiating roundabouts is significantly reduced.

Fatigue Reduction and Wear Compensation

Suspension fatigue is reduced, so helping to prevent leaf springs from sagging under repeated or constant loading.

Any sagging already present can be compensated-for. This is a particular benefit for motorhomes, which are always fully laden.

Ride Comfort

Air springs help to absorb shock loads from uneven road surfaces, therefore general ride quality is much improved.

3. VERY IMPORTANT NOTES



Gross Vehicle Weight (GVW)

Air assist kits are not in themselves designed to increase the gross vehicle weight (GVW) rating of a vehicle. They do not legally allow for carriage of a load greater than the carrying capacity stated on the data plate of the vehicle.

Do not exceed the maximum load specified by the vehicle manufacturer...

- ◆ to avoid compromising passenger safety
- ◆ to prevent possible damage to the vehicle
- ◆ for legal reasons



Load Sensing Valve (LSV) Adjustment

If your vehicle is not fitted with an antilock braking system (ABS) then it will have a load sensing valve (LSV) to automatically adjust braking force under varying load conditions. This valve **must** be adjusted immediately after the fitting of an air assist kit and before the vehicle is driven again on public roads.

If the LSV is not adjusted following the fitting of an air assist kit, it may misjudge rear load conditions to the extent that the braking pressure applied to the rear brakes is not correct (e.g. the rear wheels may lock with no load on the rear axle). The consequences of this in terms of vehicle stability and safety are potentially serious.

Vehicle Upgrading

Despite the above words of caution, it is possible to upgrade the weight rating of your vehicle. This must be carried-out by a specialist supplier that will...

- ◆ carry out any necessary modifications in addition to fitting the air assist kit
- ◆ complete documentation as necessary to inform the Vehicle and Operator Services Agency (VOSA) – a mandatory requirement
- ◆ supply and fit a new weight plate to replace the original plate supplied with the vehicle

This process applies to United Kingdom registered vehicles. The process in other countries may be different.



Nissan Navara

L.NAV.05.C.M

Safety Guidance Note

The following very useful guidance note is available for free download from the *Health and Safety Executive* (HSE)...

PM85, July 2007 *Safe recovery (and repair) of buses and coaches fitted with air suspension*

The uniform resource locator (URL) for this document is...

<http://www.hse.gov.uk/PUBNS/pm85.pdf>

Nissan Navara

L.NAV.05.C.M

4. COMPLETE ASSEMBLY

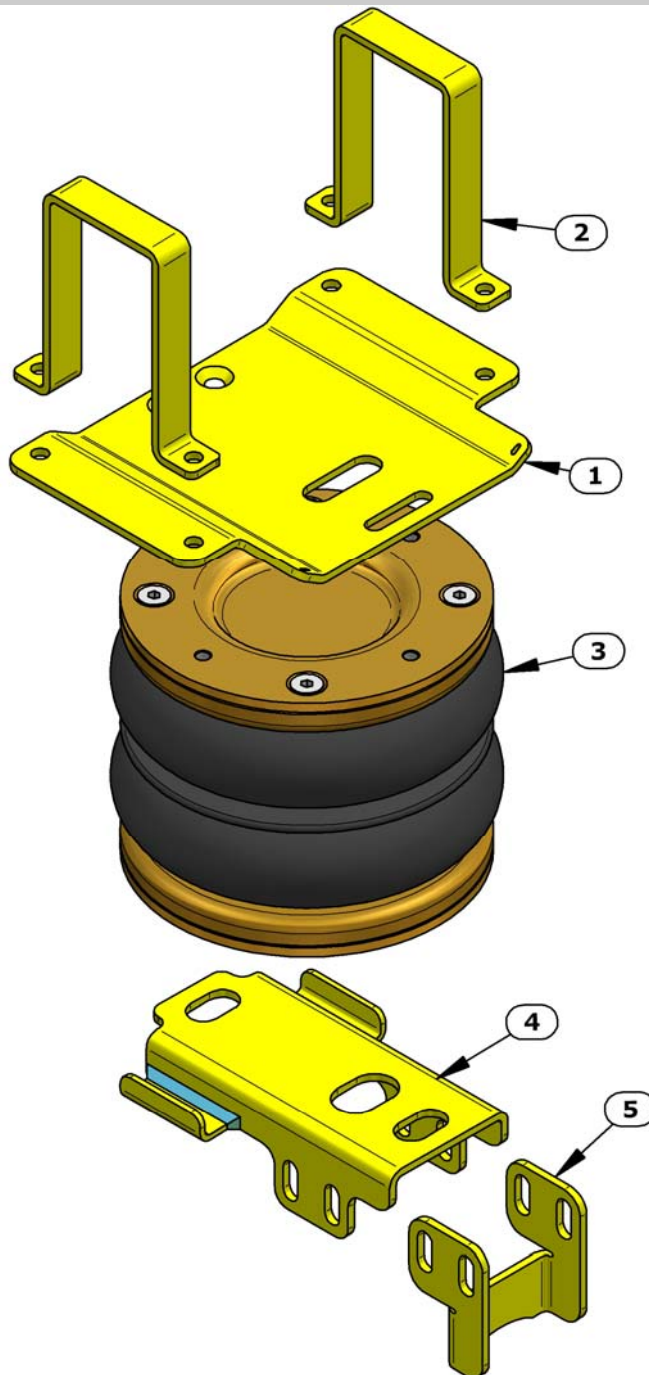

Pos. nr.	Part number	Description	Quantity
1	52.07.00.1.01.01	Upper bracket	2
2	52.07.00.1.01.02	Clamping bent plate	4
3	SA, LB.170-2	Air spring 170 / 2	2
4	52.07.00.1.04.01	Bottom bracket	2
5	21.10.00.1.04.03	Support profile	2

5. INSTRUCTIONS FOR INSTALLATION



Preparation and Precaution



Before beginning installation, ensure that you have sufficient clearance between the axle and the chassis. Use a jack if necessary. Install at one side of the vehicle at a time.



Pay attention to your safety at all times during installation - always use axle stands to support the vehicle!

The following instructions make reference to the diagrams on pages 16 to 18 inclusive.

5.1 Installation of lower plate

1. Loosen the U-bolts and remove the bump stop. (pictures 1 to 3)
2. Position the lower plate on top of the leaf springs with the longer part pointing inwards. (picture 4)
3. Tighten the U-bolts. (picture 5)
4. Push the support down on the axle and secure it. (picture 6)

5.2 Attaching the air spring to the top plate

1. Connect the air tube to the air spring .
2. Lead the tube through its designated hole of the top plate.
3. Bolt the top plate onto the air spring . Use blue for the right hand side and black for the left hand side. Pay attention to the position of the counter-sunk M8 bolt. Left and right are mirror arranged. (pictures 7 & 8)
4. Now compress the air spring and prevent the bellow from decompressing , by connecting the tube to the inflator valve.

5.3 Attaching top plate to chassis

1. Hang the clamping plates over the chassis. One in front and one behind the bump stop rebound support. (picture 9 & 10)
2. Connect the top plate with air spring to the clamps. (picture 11—13)

5.4 Attaching the air spring to the lower plate

1. Remove the inflator valve. The air spring will decompress till it touches the lower plate.
2. Place the bolts with large washers. Leave some clearance to allow aligning the air spring.

5.5 Spring Alignment

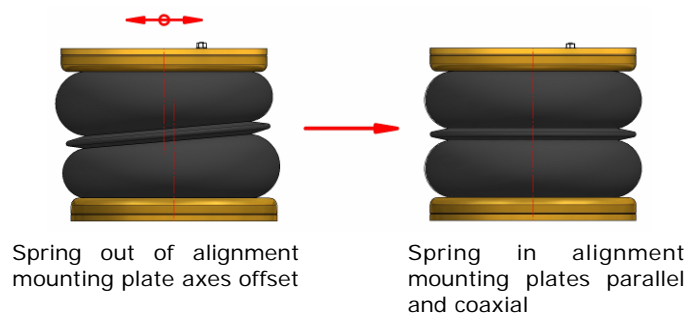

CAUTION!

Before fully tightening the bolts that secure the air spring to the upper and lower brackets, set the vehicle at ride height (spring height approximately 13.5cm) and ensure that the springs are correctly aligned.

Nissan Navara

L.NAV.05.C.M

5.6 Fitting of Inflator Console

Standard



Option 1

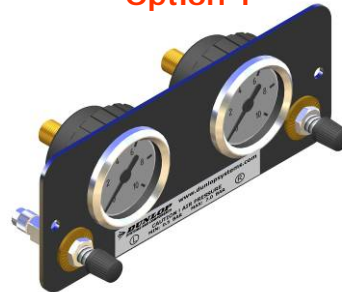

Option 2



Option 3



Not shown here, but Marcle Leisure can offer other solutions

Your kit is supplied with one of the inflator console options shown above...

- 'Standard', having two valves only (above, top-left)
- 'Option 1', 'Option 2' or 'Option 3', having both valves and pressure gauges

Mount the console in a position of your choice whereby it is firmly fixed, has some protection from the environment (particularly important for the console with gauges) and is easily accessible. Suggested possible locations include...

'Standard' Console...

- on the rear bumper
- at the rear beside the license plate
- on the chassis next to a rear wheel
- in a service shutter
- beside the fuel cap

'Option 1', 'Option 2' or 'Option 3' Console...

- in the vehicle cabin, within reach and sight of the driver
- in the wall of a cupboard (motorhomes)
- in a service shutter

'Comfort' Packages

The 'Option 2' and 'Option 3' panels, as shown above, are each part of a *Comfort Package* that is supplied with a compressor (and also an air reservoir in the case of the 'Option 3' panel) for ease of spring inflation and ride height setting. For further information please ask your dealer.

5.7 Tube Connection and Disconnection, Cutting and Routing

Connection and Disconnection

Tubes are connected as shown by the diagrams below...

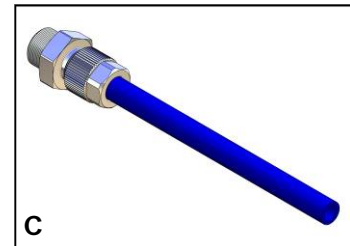
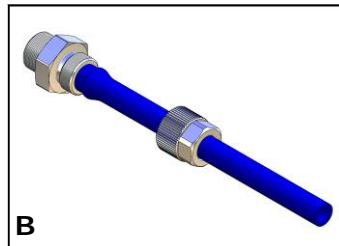
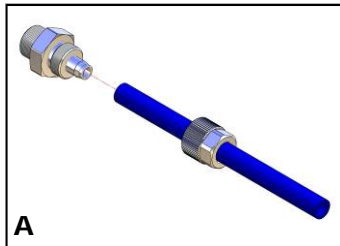

- A. Slide a nut over the end of the tube
- B. Push the tube onto the connector as far as possible
- C. Feed the nut up to the connector, fully tighten by hand and finally tighten one additional turn using spanners

Cutting

To achieve good sealing and air-tight fitting of tube ends to their connecting parts, it is very important to cut tubing cleanly and squarely. A dedicated guillotine action tubing cutter is recommended, or a craft knife if such a tool is not available. Do not use electrician's side cutters.



A dedicated tubing cutter -
Recommended



Electrician's Side Cutters
NOT Recommended



L.NAV.05.C.M

Routing

Study the underside of the vehicle and decide how to route each branch of the air circuit...

- To minimise the risk of chafing, avoid running tubing over metal edges as much as possible
- Avoid close proximity to heat sources such as the exhaust assembly
- Choose a route that provides as much protection as possible from dirt, debris and any solid objects that may impact the underside of the vehicle

It is recommended that tubes are guided alongside brake lines as much as possible.



Use cable ties ('tie wraps') to secure tubing to the chassis, taking care not to over-tighten them.

5.8 Spring Inflation

Once installation of the air assist kit is complete, inflate the springs via the inflator console taking careful note of the following...



Maximum and Minimum Pressure

Maximum Pressure 7.0bar

Minimum Pressure 0.5bar

Do not exceed 7.0bar (101psi), which is the recommended maximum charge pressure for the air springs.

The springs may be deflated if the vehicle is to be stored for a lengthy period without use, but a pressure of at least 0.5bar (7.25psi) should be maintained at all times in order to avoid possible compression damage to the springs.

5.9 Maintenance

Following installation, it is recommended that all metal parts are coated with a protective substance such as body wax.

The system does not require very much maintenance other than...

- ◆ to maintain air pressure in the springs. Much like a tyre, the system may lose a little air over time.
- ◆ to keep the air bellows clean. It is suggested that, when washing the vehicle, the bellows are inspected and cleaned as necessary (preferable by spraying). Look in particular for stones or grit trapped between convolutes, as this may damage the bellow.



Nissan Navara

L.NAV.05.C.M

5.10 Installation Drawings

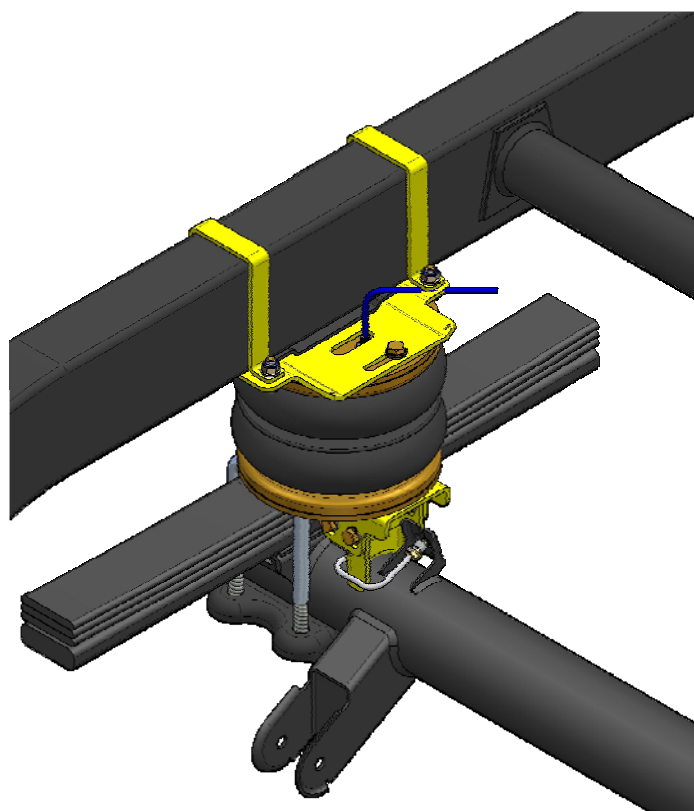

Nissan Navara
L.NAV.05.C.M

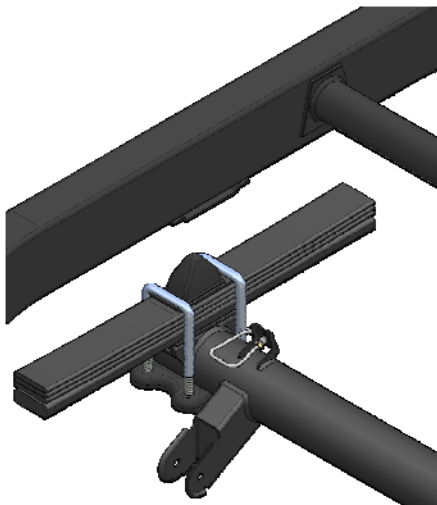

1

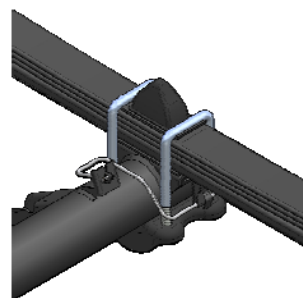

2

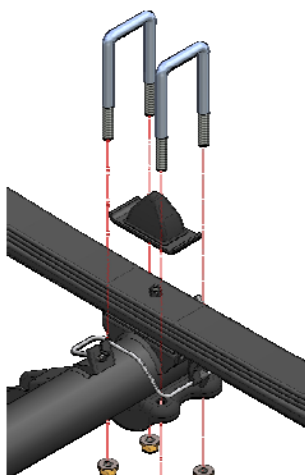

3

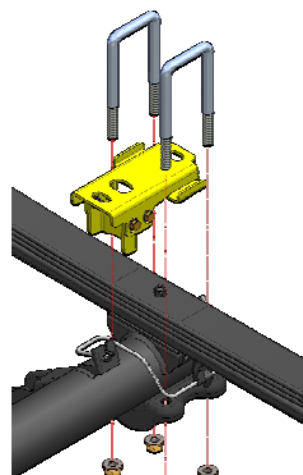

4

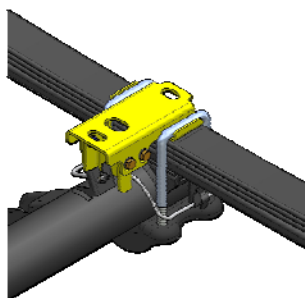

5

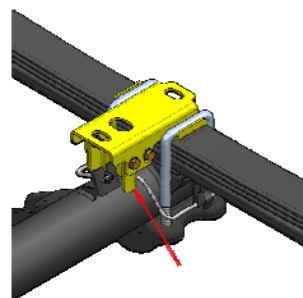

6

Nissan Navara
L.NAV.05.C.M

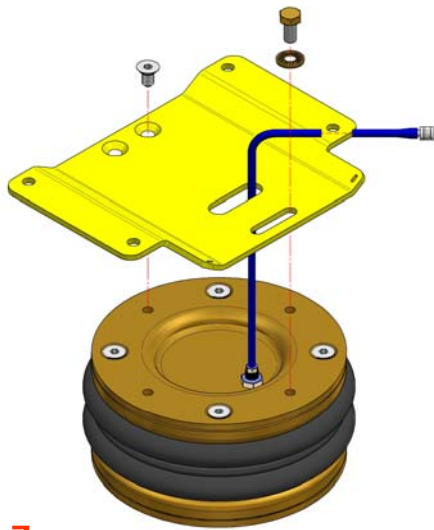

7

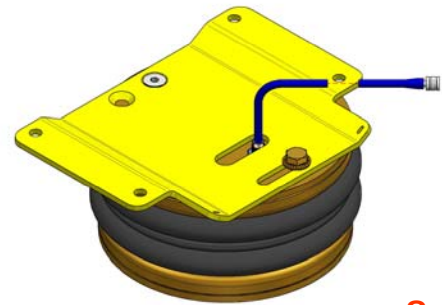

8

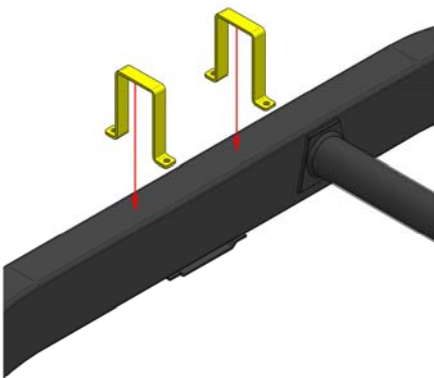

9

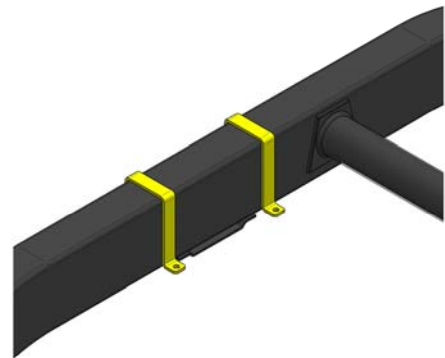

10

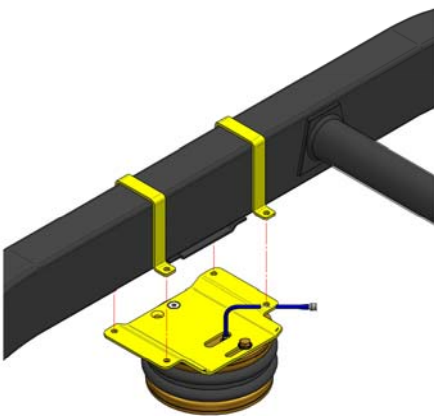

11

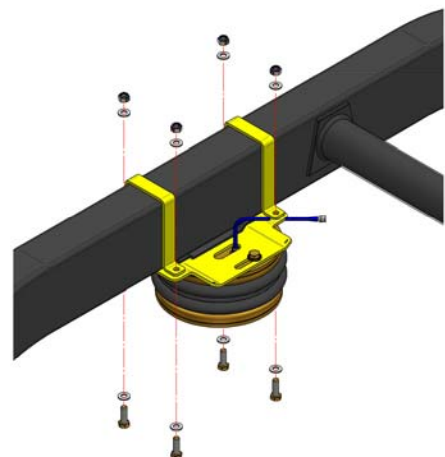

12

Nissan Navara

L.NAV.05.C.M

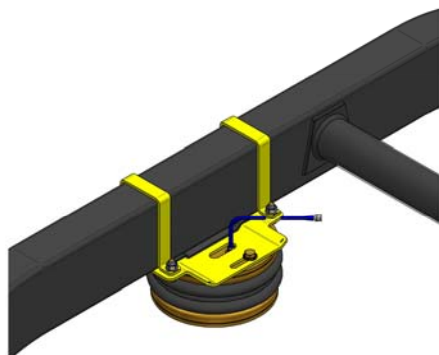

13

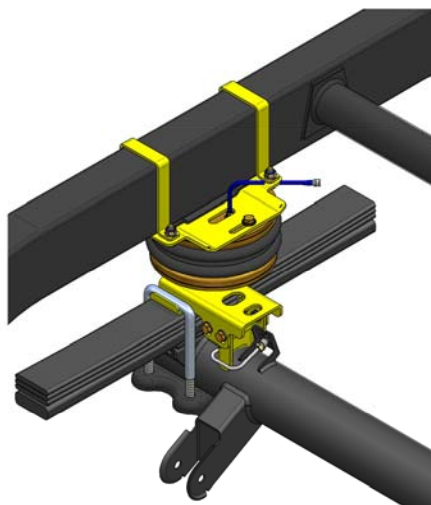

14

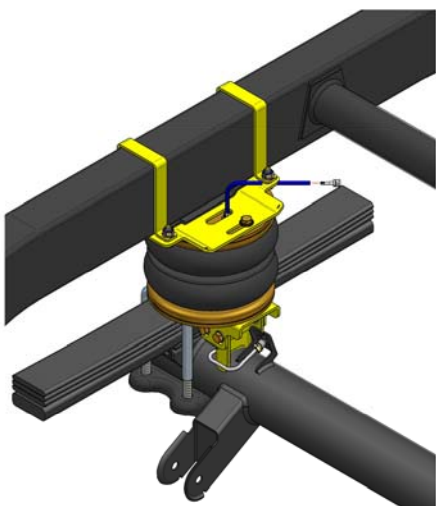

15

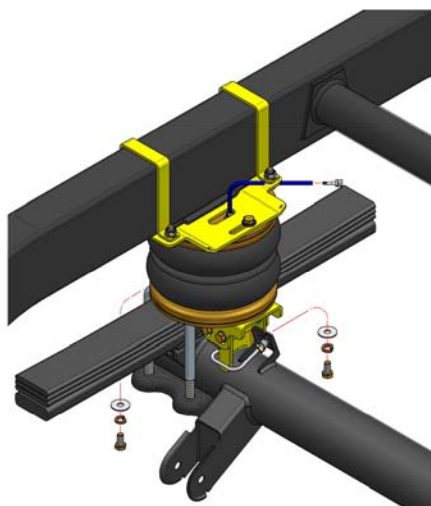

16

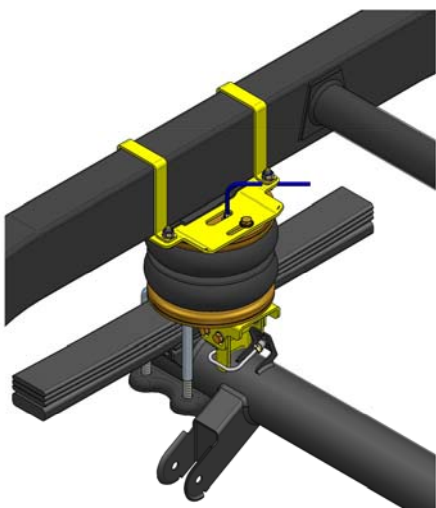

17



Nissan Navara

L.NAV.05.C.M

6. EPILOGUE

Dunlop Systems and Components hopes that you enjoy the benefits that your air suspension system will provide for you. To ensure optimal performance, we advise that you have your system checked frequently by qualified personnel. As recommended in the fitting instructions, it is important to coat all the steel parts with a protective substance such as body wax.

IMPORTANT : Manufacturer's Declaration Form

A manufacturer's declaration form is provided with your kit. Following installation of the kit please ensure that this form is completed, signed by a qualified fitter and returned to Dunlop Systems and Components.

As a condition of your warranty, modifications to the system may only be carried out by personnel of Dunlop Systems and Components.

Enquiries

For general enquiries please either telephone...

Dunlop Systems and Components Nederland : +31 (0)547 33 30 65

Dunlop Systems and Components UK : +44 (0)24 7629 3300

...or e-mail info@dunlopsystems.com.

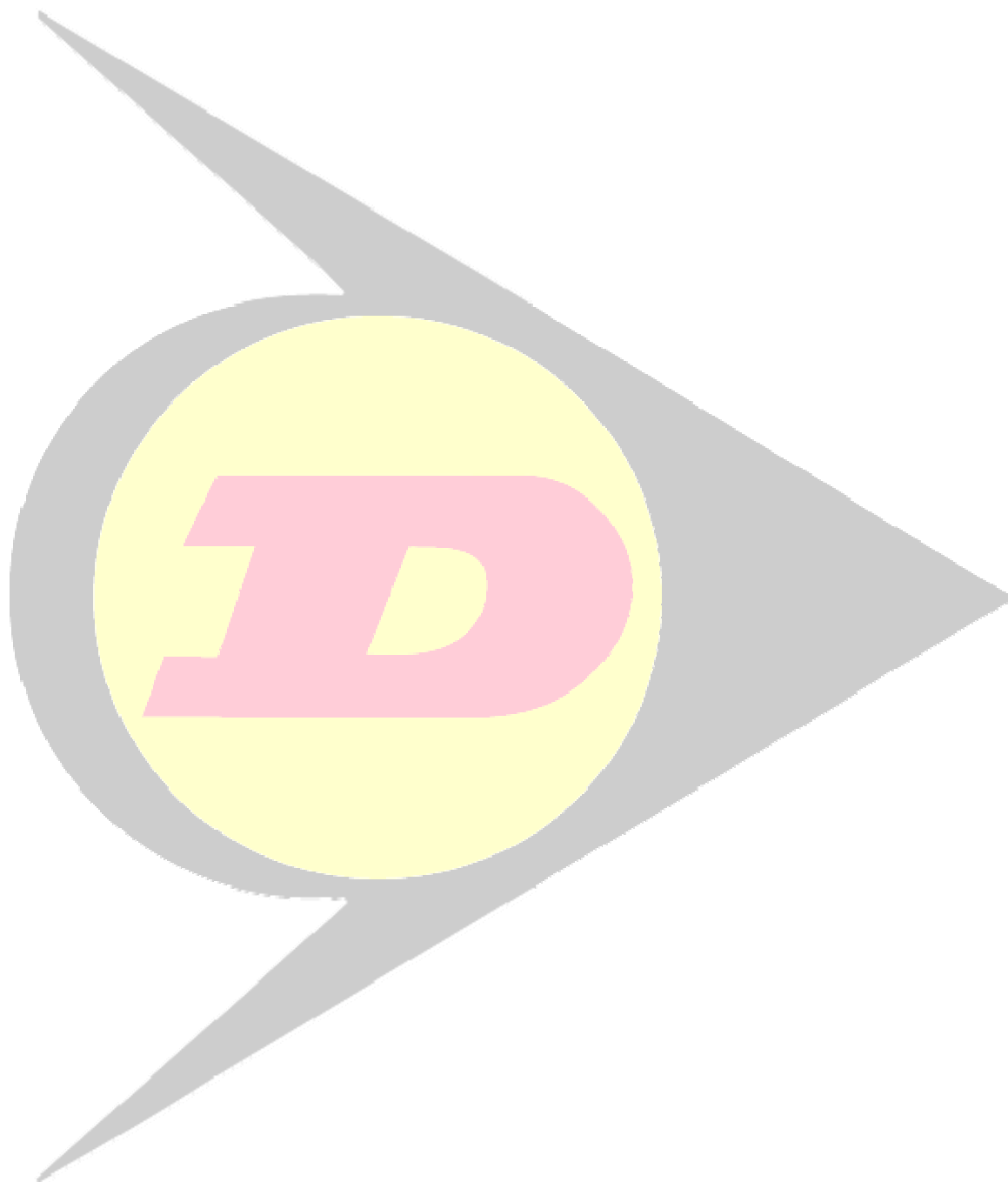

Dunlop Systems and Components
Het Wegdam 22
7496 CA Hengevelde
Nederland
Tel. +31 (0)547 33 30 65
Fax. +31 (0)547 33 30 68

Dunlop Systems and Components
Holbrook Lane
Coventry CV6 4QX
United Kingdom
Tel. +44 (0)24 7629 3300
Fax. +44 (0)24 7629 3390

www.dunlopsystems.com